

GENSET CONTROL UNIT

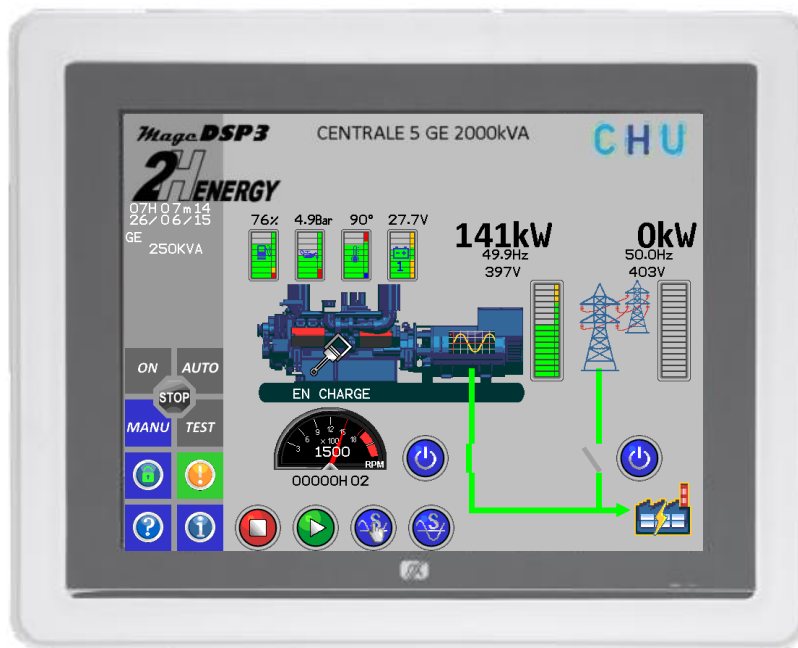

MAGE DSP 3

GENSET AND POWER PLANT CONTROL UNIT

MAGE DSP3 is dedicated to Human Machine Interface (HMI) for genset's control. It is associated with automatism MAGE DSPII+ or MAGE DSPII ND.

- ✦ Ease of use thanks to large color display,
- ✦ User-friendliness, the touchscreen allows an easy and fast access to informations,
- ✦ More functions with especially graphic records,
- ✦ More possibilities for connections (Ethernet port),

MAIN FUNCTIONS

- Synthetic display of the installation,
- Detailed display for all sub-assemblies : engine, alternator, gasoil circuit, battery circuit, mains,
- Power station state display with synoptic,
- Animated synoptics,
- Synchronoscope integrated,
- Graphic representation with bargraph or galvanometer,
- Event log of the last 512 events,
- Historical display by graphic curves,
- System parameterizing,
- 4 languages : F, GB, I, DE.
- Event log extraction in Excel™ format and screen hardcopy directly on USB key.

CARACTERISTICS

- Power supply DC 10-30V, 14W typical, 45W max
- Color display 12.1 inches color, TFT LCD
- Resolution : 800x600, brightness : 450nits
- LED backlight
- Touchscreen with resistive technology
- Fanless design
- Processor Intel® Atom™ N2600 1.6GHz
- Panel mount or VESA support
- Front bezel : IP65, NEMA 4
- Operating temperature : 0° ≈ 45°C
- Storage temperature : -30° ≈ 80°C
- Relative humidity : 10% ≈ 95% @40
- Operation vibration : 2G 5 - 500Hz
- CE-EMC : conformity class A
- Connection with : Ethernet 10/100Mbps
- Dimensions : 327.5 X 261.8 X 52.5mm Weight : 2.5kg



2H ENERGY

Parc d'Activités des Hautes Falaises – St Léonard
76400 FECAMP

Tél : +33 (0)2.35.10.68.00 Fax : +33 (0)2.35.10.68.10
contact.2he@fptindustrial.com <http://2henergy.fptindustrial.com/>



GENSET CONTROL UNIT

DISPLAY EXEMPLES

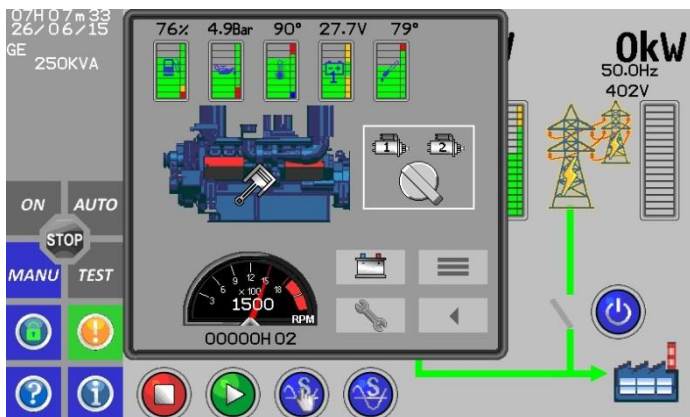

Engine informations

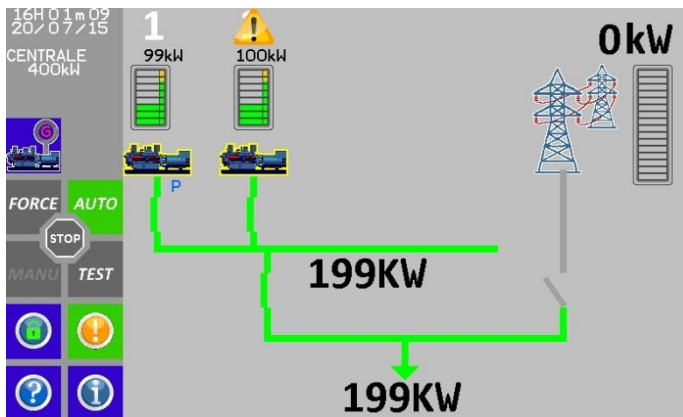

2 gensets power station synoptic

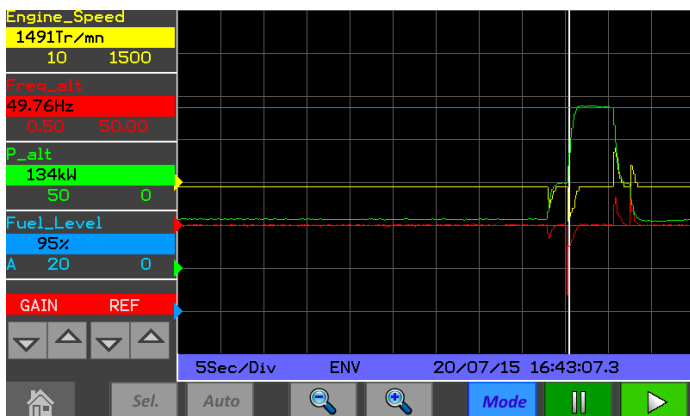

Measures graphical display

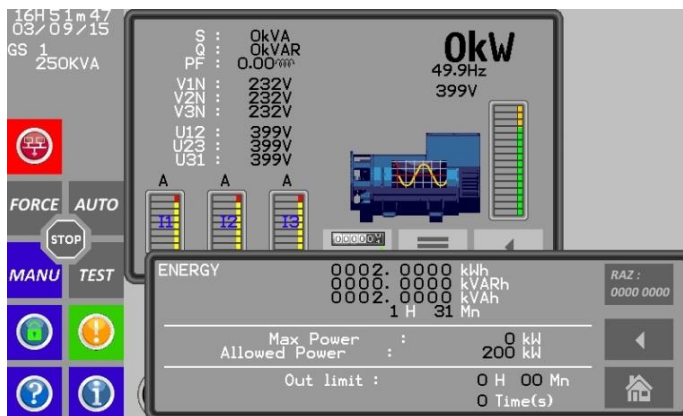

Alternator informations

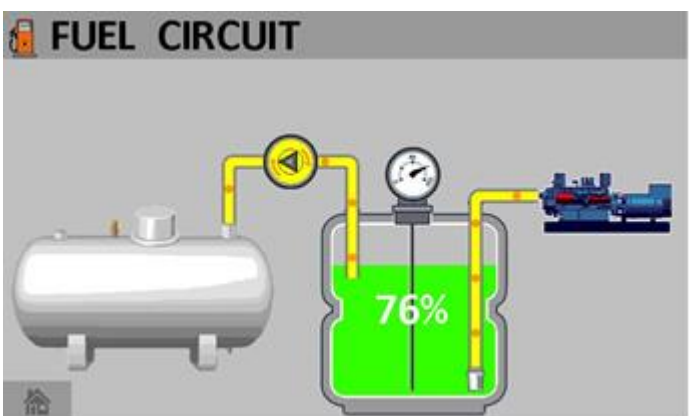

Gasoil circuit representation

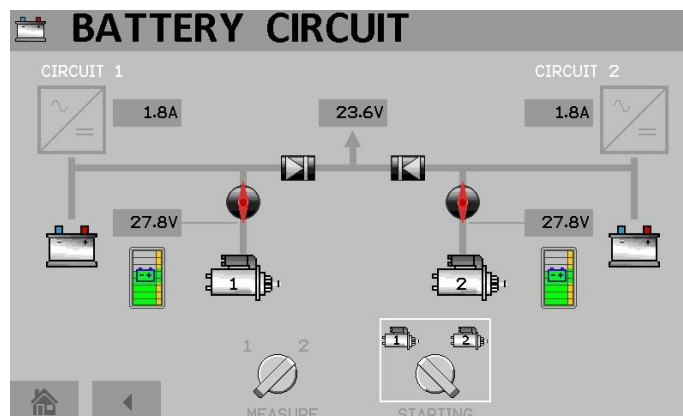

Battery circuit representation



2H ENERGY

Parc d'Activités des Hautes Falaises – St Léonard
76400 FECAMP

Tél : +33 (0)2.35.10.68.00 Fax : +33 (0)2.35.10.68.10
contact.2he@fptindustrial.com http://2henergy.fptindustrial.com/

